



User Manual of
CL7206C8 RFID Reader

Shenzhen Hopeland Technologies Co., Ltd

(V2.0.1)



Welcome to be user of Hopeland RFID products. Thanks for choosing Hopeland's 8-port Fixed RFID Reader CL7206C8. We believe our device will bring convenience for your work.

Catalogue

| | |
|--|-----------|
| Catalogue..... | 3 |
| 1. Technical Specification..... | 6 |
| 1.1 Feature..... | 6 |
| 1.2 Technical..... | 6 |
| 1.2.1 Main function..... | 6 |
| 1.2.2 Technical parameter..... | 6 |
| 1.2.3 Operational environment..... | 7 |
| 2. Sketch map..... | 8 |
| 2.1 Physical construction..... | 8 |
| 2.2 Weight..... | 8 |
| 2.3 Illustration of LED display..... | 8 |
| 2.4 Interfaces..... | 9 |
| 2.4.1 Power supply, communication and I/O interface..... | 9 |
| 2.4.2 I/O Interface definition..... | 10 |
| 2.4.3 Coaxial RF Feeder Cable (optional)..... | 12 |
| 2.4.4 Network connection diagram..... | 13 |
| 3. Installation..... | 14 |
| 3.1 Notes..... | 14 |
| 3.2 Installation conditions..... | 14 |
| 3.3 Device connection..... | 14 |
| 3.3.1 Power on..... | 14 |
| 3.3.2 Antenna connection..... | 15 |
| 3.3.3 PC connection..... | 15 |
| 3.4 Device installation..... | 15 |

| | |
|---|-----------|
| 3.5 Acceptance..... | 15 |
| 3.5.1 Acceptance of structure..... | 15 |
| 3.5.2 Performance acceptance..... | 16 |
| 4. Common failures..... | 17 |
| 4.1 Daily maintenance..... | 17 |
| 4.2 Common failure analysis and solution..... | 17 |
| 5. Package..... | 19 |
| 5.1 Package..... | 19 |
| 5.2 Accessories..... | 19 |
| 5.3 Storage environment..... | 20 |
| 6. After-sale service..... | 21 |

1. Technical Specification

1.1 Feature

CL7206C8 is a high performance eight antenna port fixed UHF RFID reader; support ISO18000-6C/6B protocols. The work frequency includes China standard dual frequency 920MHz ~ 925MHz and 840MHz ~ 845MHz, FCC 902MHz ~ 928MHz and ETSI 865MHz ~ 868MHz.

Output power from 0 ~ 33dBm optional, with long identification distance, fast reading speed, high accurate rate, strong anti-interference ability, good protection performance and easy installation.

1.2 Technical

1.2.1 Main function

- Air interface protocol: support ISO18000-6C/6B standard
- Built-in LINUX operating system
- Multiple communication port (Ethernet, RS232, RS485, USB), Wi-Fi, Bluetooth extensible
- Support tag data filtering
- Support RSSI: the intensity of the perceived signal
- Adjustable RF output power
- Optional working mode: constant frequency / frequency hopping
- Support antenna detection function
- Support online and remote upgrade
- I/O interface: 4 port optocoupler input, 4 port relay output and Wiegand output

1.2.2 Technical parameter

- Working frequency: GB 920MHz ~ 925MHz, GB 840MHz ~ 845MHz,
FCC 902MHz ~ 928MHz, ETSI 865MHz ~ 868MHz
- Output power (port): 33dBm \pm 1dB (MAX)
- Power adjustment: 1 dB step-by-step
- Reading distance: 0 ~8meters (depending on tags, antennas and environment)
- Channel bandwidth: <200 KHz
- RS232 serial communication rate: 115200bps (default), 19200 bps, 9600bps
- RS485 interface communication rate: 115200bps (default), 19200 bps, 9600bps
- Support: Wiegand 26, 34, 66 interfaces
- Power supply: 10V ~ 30V(power capacity is not less than 60W)
- Power adapter: AC input 100V ~ 240V, 50Hz ~ 60Hz
DC output: 24V/2.5A
- High protection grade: IP54

1.2.3 Operational environment

- Working environment: -20°C ~ +70°C
- Relative Humidity: 5%RH ~ 90%RH (+25°C)

2. Sketch map

2.1 Physical construction

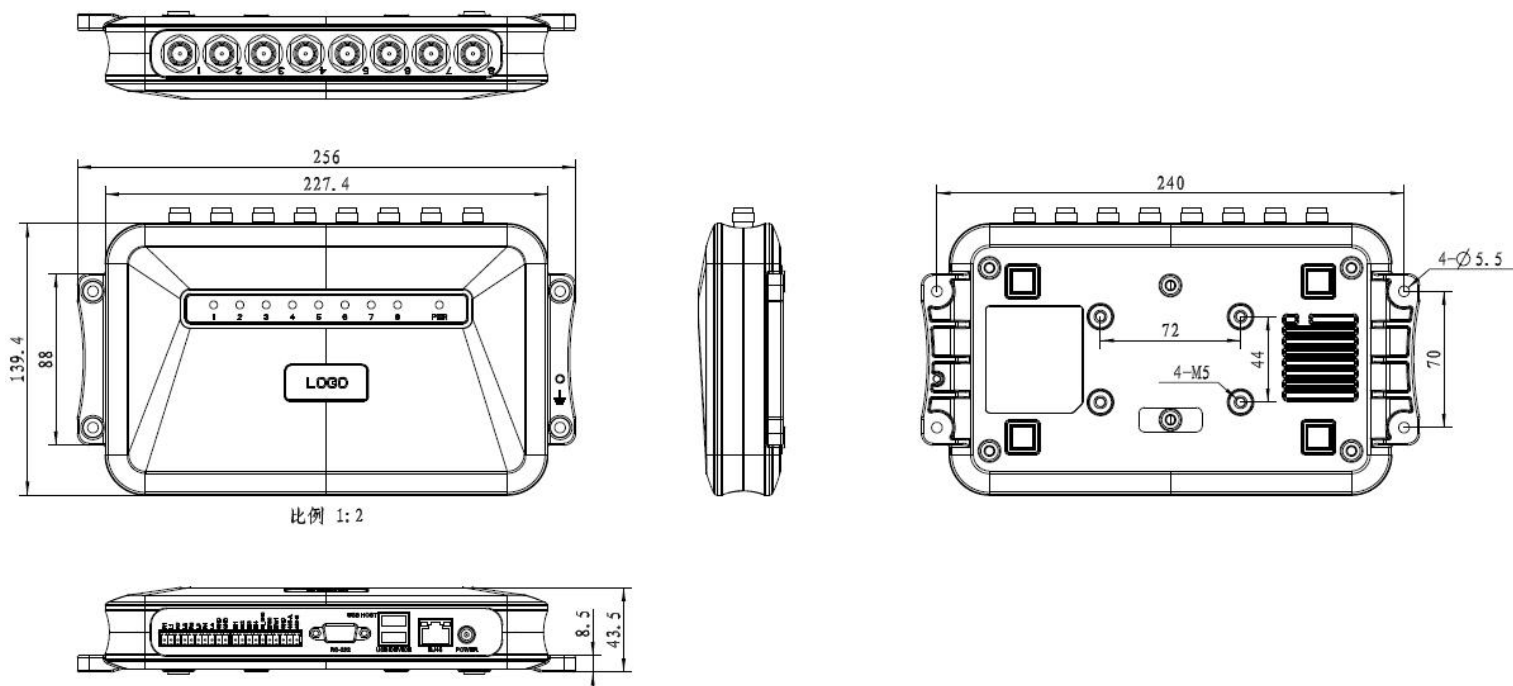

Image 2-1 Structure diagram of CL7206C8

Size: 256mm*147.6mm*43.47mm

2.2 Weight

1.41kg

2.3 Illustration of LED display



Image2-2 Sketch map of reader's LED indicator

LED indicator panel describe as below Form 2-1:

Form 2-1 LED indicator description

| LED Mark NO. | Mark NO. | Status description |
|--------------|---------------------|---|
| ANT1 | Antenna 1 indicator | Indicates antenna 1 is working |
| ANT2 | Antenna 2 indicator | Indicates antenna 2 is working |
| ANT3 | Antenna 3 indicator | Indicates antenna 3 is working |
| ANT4 | Antenna 4 indicator | Indicates antenna 4 is working |
| ANT5 | Antenna 5 indicator | Indicates antenna 5 is working |
| ANT6 | Antenna 6 indicator | Indicates antenna 6 is working |
| ANT7 | Antenna 7 indicator | Indicates antenna 7 is working |
| ANT8 | Antenna 8 indicator | Indicates antenna 8 is working |
| POWER | Power indicator | Keep bright indicates power supply working normally |

2.4 Interfaces

2.4.1 Power supply, communication and I/O interface

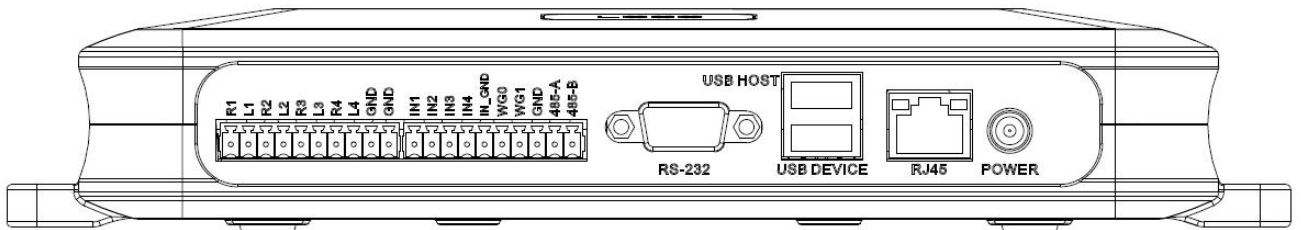

Image 2-3 Sketch map of reader's power supply, communication and I/O interface,

Details are shown in form 2-2

Form 2-2 Reader's power supply, communication and I/O interface,

| Interface ID | Interface Name | Detail description |
|--------------|--------------------|---|
| POWER | Power supply | DC,10~30V, power capacity no less than 60W. |
| RJ45 | Ethernet interface | 10/100M Ethernet interface, the reader control and communication interface. |
| USB DEVICE | USB device port | Connect PC or other upper computer, the reader control and communication interface. |
| USB HOST | USB host port | For external U disk, wireless LAN card and other expansion devices. |
| RS-232 | RS-232 serial port | Serial port, the reader control and communication interface. |
| Other | I/O interface | See detailed definition 2.4.2. |

2.4.2 I/O Interface definition

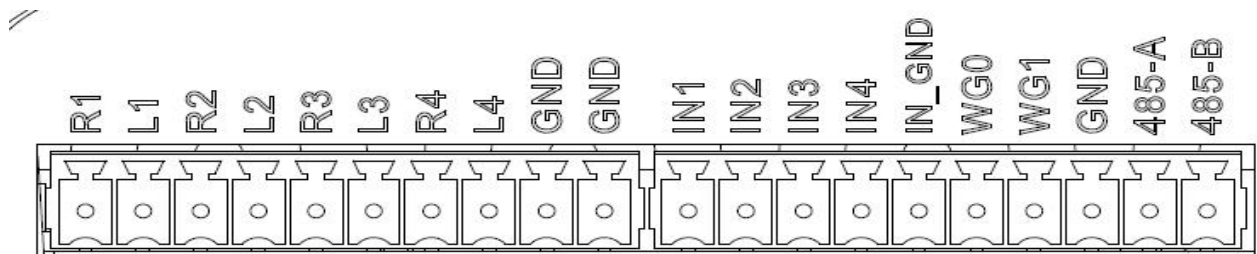

Image 2-4 Sketch map of I/O control interface

I/O control signal define as follow form 2-3

Form 2-3 I/O control signal definitions

| Pin ID | Pin Description |
|--------|--|
| R1 | Relay 1# output; DC_MAX: 30V, 2A; AC_MAX: 125V, 0.3A; logic '0' indicates open circuit, logic '1' indicates closed, default is open circuit. |

| | |
|-----|--|
| L1 | Relay 1# output; DC_MAX: 30V, 2A; AC_MAX: 125V, 0.3A; logic '0' indicates open circuit, logic '1' indicates closed, default is open circuit. |
| R2 | Relay 2# output; DC_MAX: 30V, 2A; AC_MAX: 125V, 0.3A; logic '0' indicates open circuit, logic '1' indicates closed, default is open circuit. |
| L2 | Relay 2# output; DC_MAX: 30V, 2A; AC_MAX: 125V, 0.3A; logic '0' indicates open circuit, logic '1' indicates closed, default is open circuit. |
| R3 | Relay 3# output; DC_MAX: 30V, 2A; AC_MAX: 125V, 0.3A; logic '0' indicates open circuit, logic '1' indicates closed, default is open circuit. |
| L3 | Relay 3# output; DC_MAX: 30V, 2A; AC_MAX: 125V, 0.3A; logic '0' indicates open circuit, logic '1' indicates closed, default is open circuit. |
| R4 | Relay 4# output; DC_MAX: 30V, 2A; AC_MAX: 125V, 0.3A; logic '0' indicates open circuit, logic '1' indicates closed, default is open circuit. |
| L4 | Relay 4# output; DC_MAX: 30V, 2A; AC_MAX: 125V, 0.3A; logic '0' indicates open circuit, logic '1' indicates closed, default is open circuit. |
| GND | Ground |
| GND | Ground |
| IN1 | Optocoupler 1# input, DC, 0~12V, higher than 9V is high level, lower than 8V is low level |
| IN2 | Optocoupler 2# input, DC, 0~12V, higher than 9V is high level, lower than 8V is low level |
| IN3 | Optocoupler 3# input, DC, 0~12V, higher than 9V is high level, lower than 8V is low level |
| IN4 | Optocoupler 4# input, DC, 0~12V, higher than 9V is high level, lower than |

| | |
|--------|---|
| | 8V is low level |
| IN_GND | Optocoupler input ground, reader optocoupler external input signal ground |
| WG0 | Wiegand data 0 signal, the default state is high level |
| WG1 | Wiegand data 1 signal, the default state is high level |
| GND | Ground |
| 485-A | RS485 A signal |
| 485-B | RS485 B signal |

2.4.3 Coaxial RF Feeder Cable (optional)



Image 2-6 schematic diagram of feeder line

RF cable TNC(Reverse polarity, internal thread, inner pin) connector connect with reader antenna TNC connector, RF cable SMA connector connect with external circular polarization antenna's SMA connector, cable maximum length is 5m, impedance 50Ω , insertion loss is less than 2dB, high-performance cable can also be selected, and the length can be increased appropriately, insertion loss is less than 2dB.

Note: Poor contact of cable connector or an ultra-long RF cable can cause excessive attenuation of the transmitted signal and received echo signal, resulting in deterioration of read/write performance.

2.4.4 Network connection diagram

Network interface used for long-distance high-speed connection (less than 80 m), can be connected with the switcher or router through the network cable, or directly connected with the PC network interface, as shown in figure 2-7:

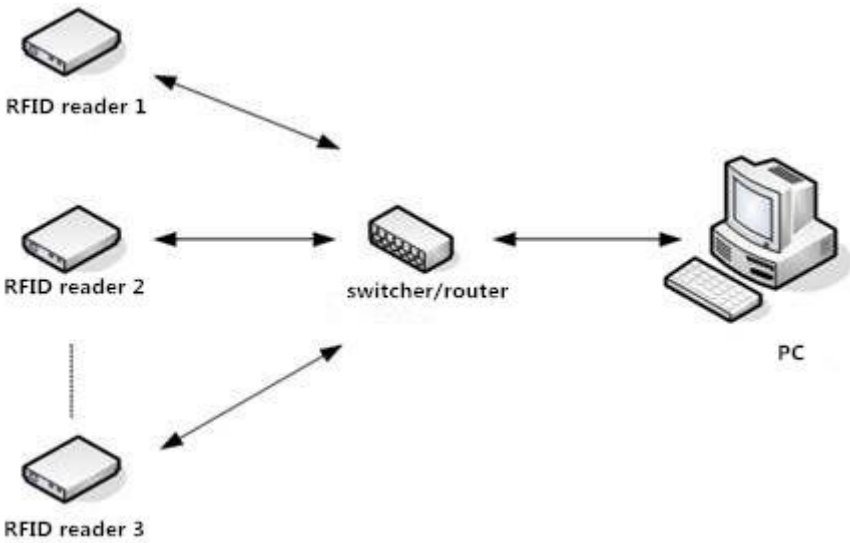

Image 2-7 Network application connection diagram

3. Installation

3.1 Notes

To ensure the normal and stable operation of the device and your personal property and safety, please carefully read the following notes before install CL7206C reader and writer:

1. Firstly, check whether the power socket is connected to the ground, and to see whether the local power supply voltage is in accordance with the applicable voltage range of the reader;
2. Check the device and the external connection if is closely connected;
3. Pay attention to the type selection and the length limit of the network cable and the serial cable:
 - Network cable connects directly, no longer than 80 meters
 - Serial cable connects directly, no longer than 10 meters
4. When installing several readers, the antenna position and the antenna spacing should be appropriate to avoid interference with each other.

3.2 Installation conditions

Before installing the reader, please check carefully whether the product is in good condition and the accessories are complete. If there is any parts missing or damage, please contact the supplier in time.

3.3 Device connection

3.3.1 Power on

Insert the power cord into the AC power supply socket and plug another end into the power connector of the device and tighten.

Turn on and wait about 20 seconds, the system initialization process is completed and is standby

state.

3.3.2 Antenna connection

The device built with four TNC coaxial cable connector for connecting an external antenna, select low consumption RF cable, connectors should be tightened (Ensure to be waterproof when install outdoors);

The reader antenna angle or tilt to adjust to the best position through the actual test according to the specific application.

3.3.3 PC connection

The device provides special adapter cable, including interface of network, serial and power,

RS232 interface is for short distance communication (less than 10m), through the DB9 connector and the PC serial port connection to realize the communication of PC and the device,

RJ45 network port used for long distance communication (less than 80m), connect PC with extend network cable.

3.4 Device installation

The reading and writing range of the reader depends on the on-site application, the tilt angle of the antenna is adjusted to achieve the best reading and writing performance.

3.5 Acceptance

Mainly from two aspects of acceptance criteria: structure and performance.

3.5.1 Acceptance of structure

Check below details:

- Whether reader is fixed firmly, without loose

- Whether the cable connected firmly
- Whether the screws are tighten

3.5.2 Performance acceptance

- Whether the reader is working properly
- Whether the read and write range is reasonable

4. Common failures

4.1 Daily maintenance

The routine maintenance of CL7206C8 usage:

- ☆To check whether the tightening of RF connector
- ☆To check if the screw fixed reader and antenna is loose
- ☆To check whether the RF cable connector is disconnected from the shielding layer
- ☆To check if the reader power cable connection is reliable

4.2 Common failure analysis and solution

Power supply system failures:

Check whether the power adapter is normal, and the AC supply voltage is between 100V ~ 240V.

The panel indicator light failed when power on:

Check whether the communication is normal; please contact customer service if it's not normal.

The serial port unable to connect:

Check if the serial cable is not connected or connected unstable.

Check if the serial port connect baud rate of the reader is correct

Check if the selected COM port is right.

The network port cannot connect:

The default IP address and port of CL7206C is 192.168.1.116:9090, ensure the IP address of the PC and reader in the same network segment, such as "192.168.1.XXX" then you can connect to the reader, if you forget the IP address of the device, you can reset the reader's IP address through the serial port.

The reader can't read the tag

Check if the setting of antenna number is correct

Check if the label is damaged

Check if the label is placed in the reader's valid reading and writing range.

Check if the electromagnetic interference between the reader and the other device.

For the problem users cannot solve, please contact customer service.

5. Package

5.1 Package

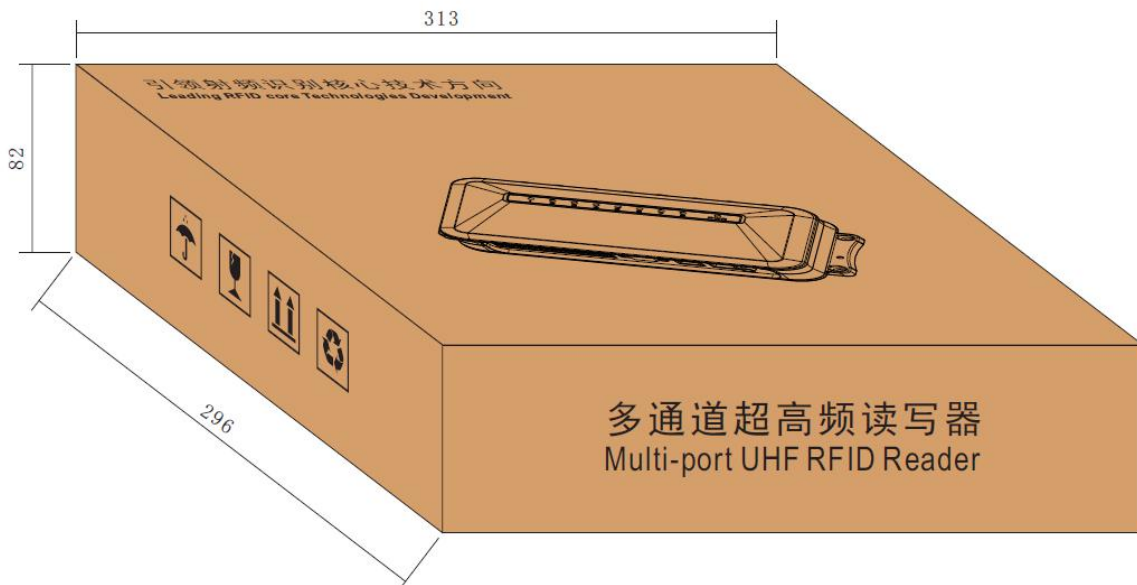

Imag5-1 Carton box size

Carton box size: 313X296X82mm

5.2 Accessories

In order to facilitate the storage and transportation in near future, the packing box and the packing material should be kept properly after unpack.

Besides of the device in the box, accessories equipped with the reader are also included in, please check the product packing list to confirm whether the product and accessories are complete, if any discrepancies or damage, please contact with the after-sale service in time.

The specific list of accessories as shown in table 5-1

Table 5-1 Package list

| NO. | Name | Material Code | Qty | Unit | Remark |
|-----|--|-----------------|-----|------|----------|
| 1 | CL7206C8 Eight-port fixed reader | _____ | 1 | set | Included |
| 2 | Power adapter 24V/2.5A | 20109000000324 | 1 | pcs | Included |
| 3 | AC power cord | 20350000000195 | 1 | unit | Included |
| 4 | Network cable | 20350000000188 | 1 | unit | Included |
| 5 | RS232 black cable | 203510000000478 | 1 | pcs | Included |
| 6 | USB cable | 203510000000036 | 1 | pcs | Included |
| 7 | 9dBi circularly polarized antenna | 203510000000035 | 8 | pcs | Optional |
| 8 | Coaxial RF Feeder Cable BRL-07 SMA-K--TNC-J reversed polarity | 203510000000814 | 8 | pcs | Optional |
| 9 | Mounting screws M4*28 | W01-104028-100 | 4 | pcs | Included |
| 10 | Warranty card | 204200000001651 | 1 | pcs | Included |
| 11 | Certificate of approval | 204200000001650 | 1 | pcs | Included |
| 12 | CD | N10-010000-002 | 1 | pcs | Optional |

5.3 Storage environment

CL7206C fixed reader should be stored in below conditions:

☆ Environment temperature: -40°C ~ +85°C

☆ Relative humidity: 5% RH ~ 95%RH

6. After-sale service

Letter to Customers

Since our aim is to continuously improve our products for better user experience, we may modify the product characteristics, composition and design of circuits without given notifications. Thus the real product may be not in accordance with this manual. Generally, we will provide timely amendments to this manual. If it's not provided timely, please consult our service department.

Shenzhen Hopeland Technologies Co., Ltd.

Email: support@hopelandrfid.com

Tell: +86-755 36901035

Website: <http://www.hopelandrfid.com>

Address: Clou Buliding, Baoshen Road, Hi-tech Park North, Nanshan District, 518057, Shenzhen, China

Guarantee card of Shenzhen Hopeland Technology Co.,Ltd

| | | | |
|-------------------------|--|-------------|--|
| Product Name | | Model No. | |
| Product Code | | Level | |
| Description of troubles | | | |
| User's name | | Postcode | |
| Contact person | | Contact no. | |

Address of factory: Block 3 of CLOU Electronics Industrial Park, Baolong Industrial City, Longgang

District ,Shenzhen, Guangdong, China

Customer service centre: +86-755 36901035

Warranty Description: In order to offer users better service, our company provide warranty card with each device, please keep it to enjoy the service.

1, Products from the date of purchase, under normal operation use without repair, one year warranty service.

2, Free maintenance won't be given under the following circumstance:

- ① The damage of the reader caused by high voltage of the power grid.
- ② The damage caused by misuse or operated improperly.
- ③ The damage caused by excessive vibration when user delivering.

3, The software of this product can be upgraded freely, users can be training in our company for free.

4, Will be charge appropriately if the user don't have a warranty card.

5, Users will need to fill out the warranty card for repair service, and sent back to Hopeland.